

PART NO.	"A" BUNDLE DIA. RANGE	"B"	"C" REF.	"D" REF.
SKL45-250	.15-.25 (3.8-6.35)	.98 (24.9)	.33 (8.5)	1.05 (26.7)
SKL45-350	.30-.40 (7.6-10.0)	1.07 (27.2)	.43 (11.0)	1.20 (30.5)
SKL45-450	.40-.47 (10.0-12.0)	1.12 (28.4)	.47 (12.0)	1.30 (33.0)

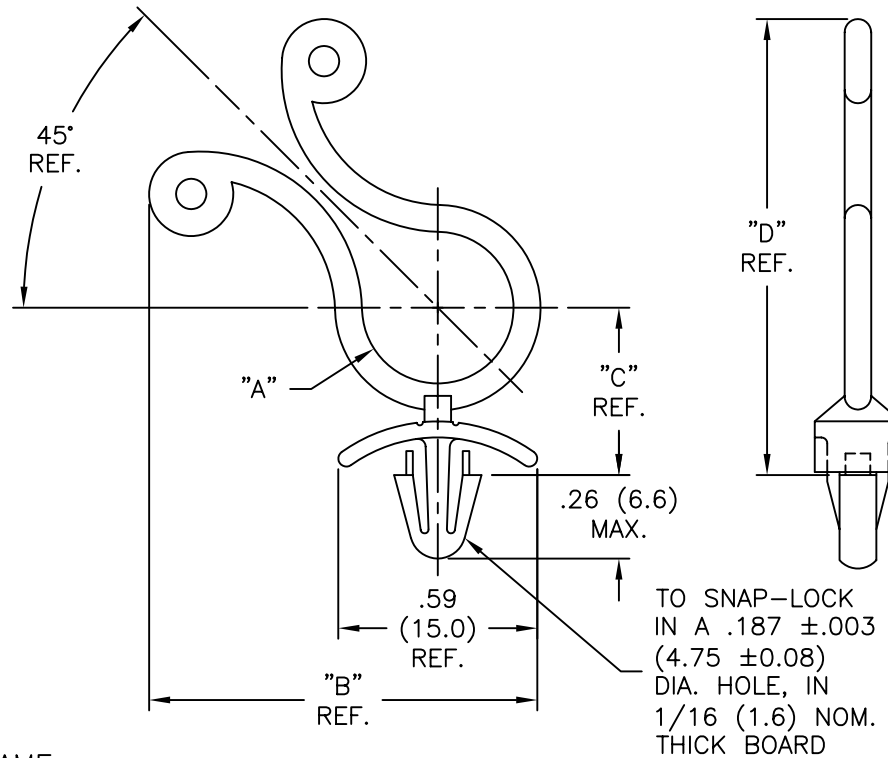

NOTES:

1. MAT'L: NYLON 66 (RMS-01), FLAME  
RETARDANT NYLON (RMS-19) BY SPECIAL  
ORDER ONLY.

COLOR: NATURAL

TITLE: STAND-OFF KURLY-LOK, 45° ANGLE			DWG IN IN (MM)		FINAL	
D	SEE ECN #1081 FOR CHANGES	SK 10.14.05	TOLERANCES UNLESS NOTED	FILE # SKL45	DWN: P.B.	DT: 04-04-95
C	CHANGED FILE NO.	SM 10.25.02	.XX=±.010	MAT'L: SEE NOTES	CHKD:	ENGR:
B	ADD FLAME RETARDANT NYLON RMS-19	AM 04.12.99	.XXX=±.005	RE: RICHCO, INC.	RICHCO INC. PO BOX 804238, CHICAGO, 60680 (773) 539-4060	
A	FILE NO. 05246 WAS 05150; CONV. TO ACAD; .15-.25 WAS .20-.30; .40-.47 WAS .40-.50	PB 04.04.95	FRAC=±1/64	PART # SEE TABLE		PRINT TYPE CA
REV	DESCRIPTION	ENGR DATE	ANG=±1°			